

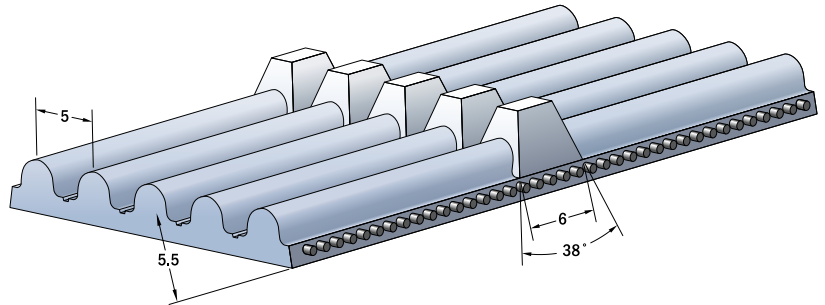

HTD5V™ SELF TRACKING BELT

Gates® HTD5V with integral K6 V-guide eliminates lateral movement for applications without pulley flanges and/or experiencing side forces.



SPECIFICATIONS

Pitch	5 mm
Standard Thickness	5.5 mm
Minimum Welded Belt Length	1000 mm
Standard Roll Length (Tolerance ±1%)	100 m
Standard Color	White
Cord	Steel Cord / Aramid Cord
Minimum Number of Pulley Teeth z_{min}	25 (Steel/ Aramid)
Minimum Back Bend Diameter	100 mm (Steel/ Aramid)
FDA / EU Approval	Option
Polyurethane	R1 / 92 Shore A / -5°C to +70°C
Polyamide Fabric	Optional NT, NB & NTB

Technical Data

Standard Width [mm]	20	25	30	50
Ultimate Tensile Strength [N] Average Value				
Steel	8060	10540	12400	21700
Aramid	6360	8085	9810	16709
Allowable Belt Tension [N] Open Ended				
Steel	1789	2340	2753	4818
Aramid	837	1064	1290	2198
Allowable Effective Tension [N] Endless Welded				
Steel	895	1170	1376	2409
Aramid	627	798	968	1648
Allowable Effective Tension [N] Minimum 15 Teeth are in mesh				
	571	775	979	1795
Specific Belt Stiffness [N]				
Steel	447353	585000	688235	1204412
Aramid	209155	265875	322595	549475

UNITED STATES
 9 Northwestern Drive,
 Salem, NH 03079
 Tel +1 (800) 394-4844
 Email: contact@gatesmectrol.com

EUROPE
 Werner von Siemens Straße 2
 64319 Pfungstadt, Germany
 Tel. +49 (0) 6157-9727-0
 Email: info@gatesmectrol.de