

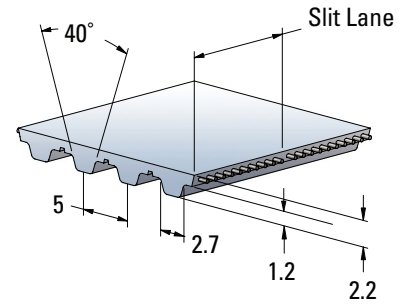

T5 REINFORCED BELT 150MM

T5 Aramid or Steel reinforced belts are now available from Gates TPU in widths up to 150mm.

This belt is commonly used in conveying applications.



SPECIFICATIONS

Product Data

Pitch	5 mm
Standard Thickness	2.2 mm
Minimum Welded Belt Length	450 mm
Standard Roll Length (Tolerance ±1%)	100 m
Color	Natural (White Available)
Minimum Number of Pulley Teeth	10
Minimum Pulley Diameter	16 mm
Minimum Back Bend Diameter	30 mm
FDA/EU Approval	Option
Polyurethane	92 Shore A
Polyamide Fabric	NT & NTB

Technical Data

Cord	Aramid	Steel
Ultimate Tensile Strength - N/25 mm	5332	3375
Max Allowable Belt Tension - N/25 mm	801 (Open Ended) 687 (Welded)	840 (Open Ended) 420 (Welded)
Allowable Effective Tension - N/25 mm (15 or More Teeth in Mesh)	890	890
Specific Belt Weight (kg/m/cm)	0.020	0.022
Specific Belt Stiffness (N/mm)	9155	8400

UNITED STATES

9 Northwestern Drive
Salem, NH 03079
P +1 (800) 394-4844
E contact@gatesmectrol.com

EUROPE

Werner von Siemens Strasse 2
64319 Pfungstadt, Germany
P: +49 (0) 6157-9727-0
E: info@gatesmectrol.de

GATES.COM
GATESMECTROL.COM