



# TPU BELTS

THERMOPLASTIC POLYURETHANE

## CENTERCLEAN™ FOOD GRADE BELTING

CenterClean is a center driven food processing belt appropriate for general food processing and troughing applications.

CenterClean self-tracking belts are constructed with flexible urethane and sealed Kevlar™ tension members. This construction allows CenterClean belts to be troughed or run on small diameter pulleys with minimal belt stretch. The smooth surfaces facilitate cleaning to a microbial level.

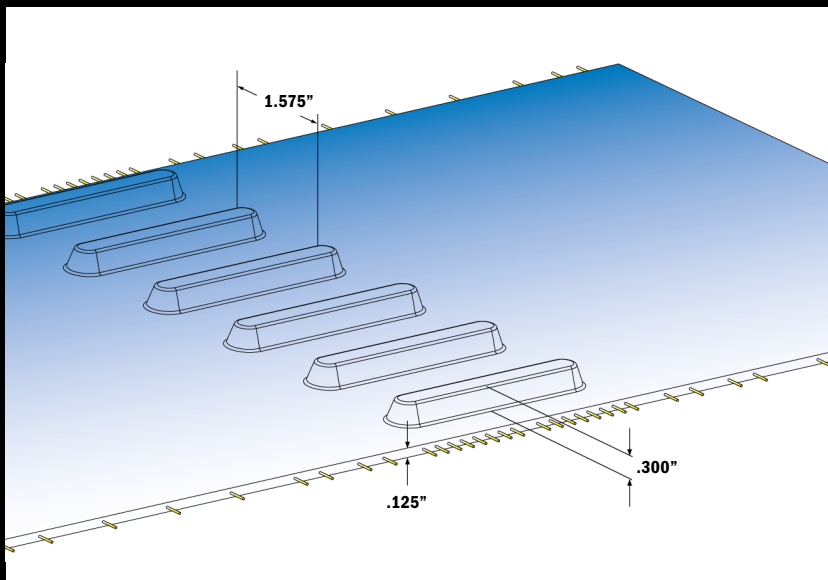

CC40

CenterClean belting has drive teeth only in the center three inches of the belt and a pitch length of 1.575" (40 mm). The lack of extended teeth makes this belt appropriate for self-tracking and troughing applications as well as general processing.

### FEATURES

- Clean-in-place process
- Urethane material compatible with wash down environments
- Kevlar tension members provide high strength, low stretch
- Sealed edges and tension members prevent ingress of microbes
- Can be welded endless or spliced with stainless steel or PosiLace™ pin system
- USDA accepted for meat, poultry and dairy processing equipment

### BENEFITS

- Reduction of in-process bacteria growth
- Cut water usage and costs by 45%
- Longer belt life due to minimal belt stretch
- Reduce cleaning time by 50%



# TPU BELTS

THERMOPLASTIC POLYURETHANE

## CC40 + CC40D SPECIFICATIONS

SPECIFICATIONS	STANDARD		METAL DETECTABLE	
	METRIC	IMPERIAL	METRIC	IMPERIAL
Designator	KV-FDA		KV-FMD	
Pitch	40mm	1,575"	40mm	1,575"
Hardness - Shore A:	95			
Surface Textures:	Smooth, IP, IT			
Specific belt weight kg/m <sup>2</sup>	4.6		5	
Specific belt weight lbs/in	0.078		0.084	
Specific belt stiffness N/mm	1296		1296	
Specific belt stiffness lbs/in	7400		7400	
Min. Sprocket Dia. Service Temp above -4°C / 25°F	124mm	4,9"	150mm	5,9"
Min. Sprocket Dia. Service Temp below -4°C / 25°F	152mm	6"	152mm	6"
Min. Back Bend Dia. above -4°C / 25°F	152mm	6"	152mm	6"
Min. Back Bend Dia. below -4°C / 25°F	254mm	10"	254mm	10"
Service Temperature Range °C	-18° to 71°C		-18° to 71°C	
Service Temperature Range °F	+0° to 160°F		+0° to 160°F	
Color	PosiBlue, PosiWhite		PosiBlue	
Min widths	152mm	6"	152mm	6"

STANDARD WIDTHS	cm	45.7	61.0	76.2	81.3	91.4	121.9
	inch	18	24	30	32	36	48
Standard	N/A	x	x	x	x	x	x
Metal detectable	N/A	x	x	x	x	x	x

FASTENING OPTIONS SINGLE TRACK	lbs/inch	STANDARD				METAL DETECTABLE			
		6-9"	>9-12"	>12-17"	>17-36"	6-9"	>9-12"	>12-17"	>17-36"
Max. Allowable Tension (N/cm width) (lbs/inch width) <sup>(1)</sup>									
Platen Weld (Finger 30mm x 70 mm)	239	275	317	344	191	220	254	275	
Butt Weld	203	233	269	292	186	214	247	268	
Flexco® UX1SS Clipper® Wire Hooks	239	275	317	344	186	214	247	268	
Flexco APF150 Alligator® Plastic Rivet	139	160	184	199	N/A	N/A	N/A	N/A	
Flexco RS125 Alligator Ready Set™ Staple	290	334	385	417	156	180	208	226	
PosiLace	155	179	206	223	N/A	N/A	N/A	N/A	

FASTENING OPTIONS SINGLE TRACK	N/cm	STANDARD				METAL DETECTABLE			
		152-229	>229-305	>305-432	>432-914	152-229	>229-305	>305-432	>432-914
Max. Allowable Tension (N/cm width) (lbs/inch width) <sup>(1)</sup>									
Platen Weld (Finger 30mm x 70 mm)	418	482	555	602	334	385	445	482	
Butt Weld	355	408	471	511	326	375	433	469	
Flexco UX1SS Clipper Wire Hooks	418	482	555	602	326	375	433	469	
Flexco APF150 Alligator Plastic Rivet	243	279	322	349	N/A	N/A	N/A	N/A	
Flexco RS125 Alligator Ready Set Staple	508	584	674	730	273	315	364	396	
PosiLace	272	313	361	391	N/A	N/A	N/A	N/A	

(1) Max allowable set as the lower of 25% yield strength or 2% stretch of weld or splice

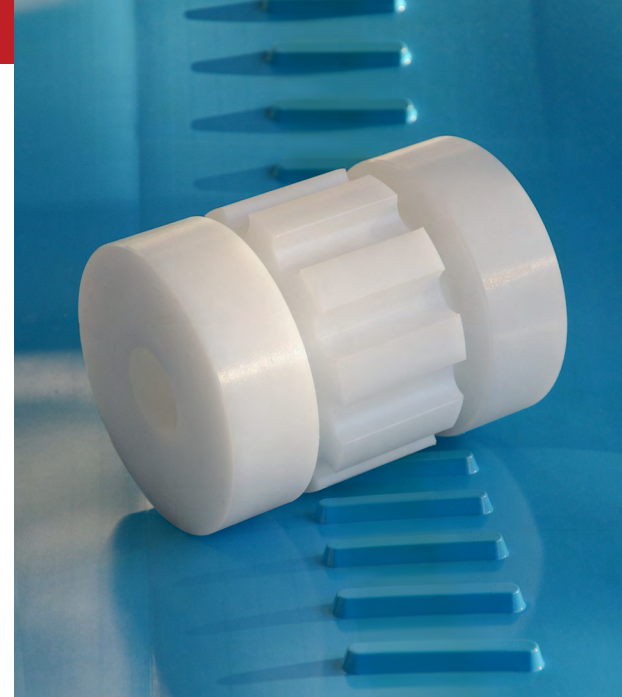

FASTENING OPTIONS DUAL TRACK	lbs/inch	STANDARD			METAL DETECTABLE		
		>30-39"	>39-42"	>42-48"	>30-39"	>39-42"	>42-48"
Max. Allowable Tension (N/cm width) (lbs/inch width) <sup>(1)</sup>							
Butt Weld		724	766	793	658	697	721
Flexco UX1SS Clipper Wire Hooks		724	766	793	658	697	721
Flexco APF150 Alligator Plastic Rivet		419	443	458	N/A	N/A	N/A
Flexco RS125 Alligator Ready Set Staple		878	929	961	474	502	519
PosiLace		471	498	N/A	N/A	N/A	N/A

FASTENING OPTIONS DUAL TRACK	N/cm	STANDARD			METAL DETECTABLE		
		>762-991	>991-1067	>1067-1219	>762-991	>991-1067	>1067-1219
Max. Allowable Tension (N/cm width) (lbs/inch width) <sup>(1)</sup>							
Butt Weld		1268	1341	1389	1152	1221	1263
Flexco UX1SS Clipper Wire Hooks		1268	1341	1389	1152	1221	1263
Flexco APF150 Alligator Plastic Rivet		734	776	802	N/A	N/A	N/A
Flexco RS125 Alligator Ready Set Staple		1538	1627	1683	830	879	909
PosiLace		825	872	N/A	N/A	N/A	N/A

### CENTERCLEAN SPROCKET SPECIFICATIONS

SPECIFICATIONS	BELT TYPE	CC40								
		NO OF TEETH	10	11	12	13	15	16	17	20
Nom. Outside Diameter	mm		124	137	150	163	188	201	213	251
	inch		4.9	5.4	5.9	6.4	7.4	7.9	8.4	9.9
Nominal Width	mm		165							
	inch		6.5							
Available Bore Size	imperial square		1.5							
Material	metric round		UHMW-PE							

\* Imperial keyway sizes on round bores conform to ANSI standard B17.1 - 1967 (R1989); metric keyway sizes conform to BS 4235: Part 1: 1972 (1986)

CenterClean Sprocket

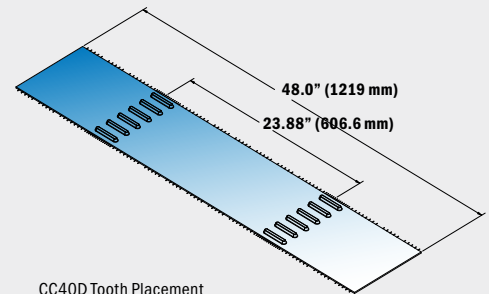

CC40D Tooth Placement

### CENTERCLEAN CARRYWAY SUPPORT GUIDELINES

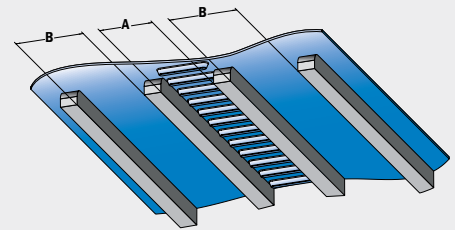

Distance Between Parallel Wear Strips  
Guiding Belt Teeth, Dim. A: 3.15" (80 mm)

Distance Between Parallel Wear Strips  
Not Guiding Belt Teeth, Dim. B: 4" - 6" (100 mm - 150 mm)

**NORTH AMERICA**  
Gates TPU  
9 Northwestern Drive  
Salem, NH 03079  
Tel. +1(800) 394-4844  
Email: [contact@gates.com](mailto:contact@gates.com)

**EMEA**  
Gates TPU GmbH  
Wermervon Siemens Strasse 2  
64319 Pfungstadt, Germany  
Tel. +49 (0) 6157-9727-0  
Email: [sales-pfungstadt@gates.com](mailto:sales-pfungstadt@gates.com)